

HC-SR501 PIR MOTION DETECTOR

Product Description

HC-SR501 is based on infrared technology, automatic control module, using Germany imported LHI778 probe design, high sensitivity, high reliability, ultra-low-voltage operating mode, widely used in various auto-sensing electrical equipment, especially for battery-powered automatic controlled products.

Specification:

- Voltage: 5V – 20V
- Power Consumption: 65mA
- TTL output: 3.3V, 0V
- Delay time: Adjustable (.3->5min)
- Lock time: 0.2 sec
- Trigger methods: L – disable repeat trigger, H enable repeat trigger
- Sensing range: less than 120 degree, within 7 meters
- Temperature: – 15 ~ +70
- Dimension: 32*24 mm, distance between screw 28mm, M2, Lens dimension in diameter: 23mm

Application:

Automatically sensing light for Floor, bathroom, basement, porch, warehouse, Garage, etc, ventilator, alarm, etc.

Features:

- Automatic induction: to enter the sensing range of the output is high, the person leaves the sensing range of the automatic delay off high, output low.
- Photosensitive control (optional, not factory-set) can be set photosensitive control, day or light intensity without induction.
- Temperature compensation (optional, factory reset): In the summer when the ambient temperature rises to 30 ° C to 32 ° C, the detection distance is slightly shorter, temperature compensation can be used for performance compensation.
- Triggered in two ways: (jumper selectable)
 - non-repeatable trigger: the sensor output high, the delay time is over, the output is automatically changed from high level to low level;
 - repeatable trigger: the sensor output high, the delay period, if there is human activity in its sensing range, the output will always remain high until the people left after the delay will be high level goes low (sensor module detects a time delay period will be automatically extended every human activity, and the starting point for the delay time to the last event of the time).
- With induction blocking time (the default setting: 2.5s blocked time): sensor module after each sensor output (high into low), followed by a blockade set period of time, during this time period sensor does not accept any sensor signal. This feature can be achieved sensor output time "and" blocking time "interval between the work can be applied to interval detection products; This function can inhibit a variety of interference in the process of load switching. (This time can be set at zero seconds – a few tens of seconds).
- Wide operating voltage range: default voltage DC4.5V-20V.
- Micropower consumption: static current <50 microamps, particularly suitable for battery-powered automatic control products.
- Output high signal: easy to achieve docking with the various types of circuit.

Adjustment:

- Adjust the distance potentiometer clockwise rotation, increased sensing distance (about 7 meters), on the contrary, the sensing distance decreases (about 3 meters).
- Adjust the delay potentiometer clockwise rotation sensor the delay lengthened (300S), on the contrary, shorten the induction delay (5S).

Instructions for use:

- Sensor module is powered up after a minute, in this initialization time intervals during this module will output 0-3 times, a minute later enters the standby state.
- Should try to avoid the lights and other sources of interference close direct module surface of the lens, in order to avoid the introduction of interference signal malfunction; environment should avoid the wind flow, the wind will cause interference on the sensor.
- Sensor module with dual probe, the probe window is rectangular, dual (A B) in both ends of the longitudinal direction
 - so when the human body from left to right or right to left through the infrared spectrum to reach dual time, distance difference, the greater the difference, the more sensitive the sensor,
 - when the human body from the front to the probe or from top to bottom or from bottom to top on the direction traveled, double detects changes in the distance of less than infrared spectroscopy, no difference value the sensor insensitive or does not work;
- The dual direction of sensor should be installed parallel as far as possible in inline with human movement. In order to increase the sensor angle range, the module using a circular lens also makes the probe surrounded induction, but the left and right sides still up and down in both directions sensing range, sensitivity, still need to try to install the above requirements.

HC-SR501 PIR MOTION DETECTOR

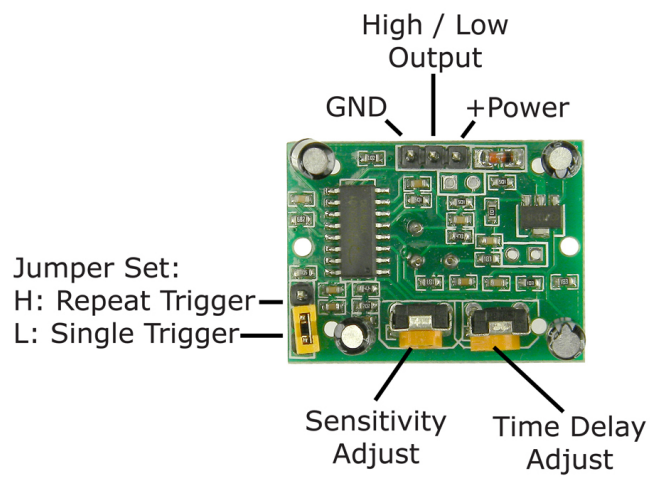
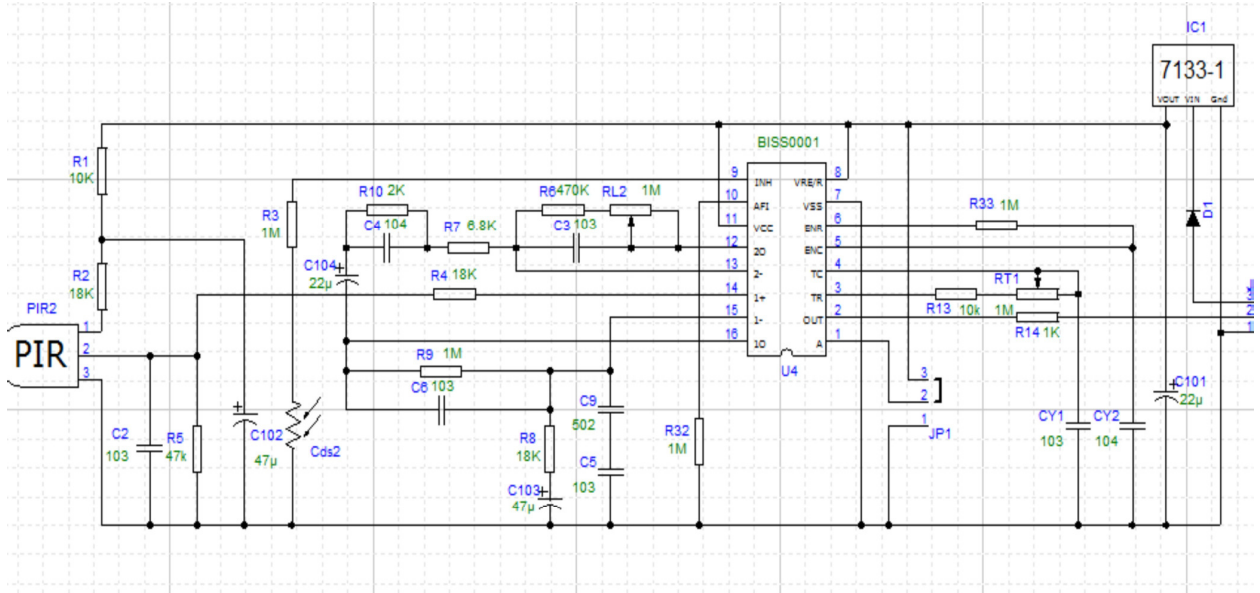

-
- 1 working voltage range :DC 4.5-20V
 - 2 Quiescent Current :50uA
 - 3 high output level 3.3 V / Low 0V
 4. Trigger L trigger can not be repeated / H repeated trigger
 5. circuit board dimensions :32 * 24 mm
 6. maximum 110 ° angle sensor
 7. 7 m maximum sensing distance

Product Type	HC--SR501 Body Sensor Module
Operating Voltage Range	5-20VDC
Quiescent Current	<50uA
Level output	High 3.3 V /Low 0V
Trigger	L can not be repeated trigger/H can be repeated trigger(Default repeated trigger)
Delay time	5-300S(adjustable) Range (approximately .3Sec -5Min)
Block time	2.5S(default)Can be made a range(0.xx to tens of seconds
Board Dimensions	32mm*24mm
Angle Sensor	<110 ° cone angle
Operation Temp.	-15-+70 degrees
Lens size sensor	Diameter:23mm(Default)

Application scope

- Security products
- Body induction toys
- Body induction lamps
- Industrial automation control etc

Pyroelectric infrared switch is a passive infrared switch which consists of BISS0001 ,pyroelectric infrared sensors and a few external components. It can open all kinds of equipments, including incandescent lamp, fluorescent lamp, intercom, automatic, electric fan, dryer and automatic washing machine, etc. It is widely used in enterprises, hotels, stores, and corridor and other sensitive area for automatical lamplight, lighting and alarm system.

Instructions

Induction module needs a minute or so to initialize. During initializing time, it will output 0-3 times. One minute later it comes into standby.

Keep the surface of the lens from close lighting source and wind, which will introduce interference.

Induction module has double -probe whose window is rectangle. The two sub-probe (A and B) is located at the two ends of rectangle. When human body r to right, or from right to left, Time for IR to reach to reach the two sub-probes differs.The larger the time difference is, the more sensitive this module is. Wh body moves face-to-probe, or up to down, or down to up, there is no time difference. So it does not work. So instal the module in the direction in which most activities behaves, to guarantee the induction of human by dual sub-probes. In order to increase the induction range, this module uses round lens which ca from all direction. However, induction from right or left is more sensitivity than from up or down.